

Katalog

Ausgabe: 2020

Stanzwerkzeuge



MUBEA

Dieser Katalog zeigt – in klarer Gliederung – das komplette Mubea-Programm über genormte Stempel und Matrizen für die rationelle Blech-, Flach- und Profilstahlbearbeitung. Alle hier aufgeführten Werkzeuge sind kurzfristig lieferbar.

Alle Werkzeuge dieses Kataloges sind für die Bearbeitung von Material bis zu einer Festigkeit von 600 N/mm² geeignet. Werkzeuge zur Bearbeitung von Material mit höherer Festigkeit werden auf Wunsch gesondert gefertigt.

Bei den in diesem Katalog aufgeführten Langlochwerkzeugen entspricht der Radius der halben Lochbreite. Falls erforderlich, abweichende Radien bitte angeben. Diese Werkzeuge werden in Sonderanfertigung hergestellt.

Für jedes Werkzeug bitte die komplette Artikel-Nummer angeben.

Bestell-Beispiel:

Stempel 50505 1

Schnittform: Rund

10 Stück Abmessung: 3,0 mm

Die Größe des zu stanzenden Loches wird durch die Abmessung des Stempels bestimmt. Die Stempel sind mit diesem Maß gekennzeichnet.

Die Öffnung der Matrize muss um das Schneidspiel (= 2x Schneidspalt) größer sein. Erfahrungsgemäß sollte das Schneidspiel ca. 10% der Materialstärke betragen. Die Kennzeichnung der Matrize gibt die tatsächliche Abmessung der Schneidöffnung (Öffnung in der Matrize) an.

Bei der Festlegung des Schneidspiels empfehlen wir folgende Regeln:

Für runde und quadratische Schnittform:

Materialstärke: mm	bis 4	> 4 bis 9	> 9 bis 14	> 14 bis 19	> 19 bis 24
Schneidspiel: mm	0,2	0,7	1,2	1,7	2,2

Beispiel: Stempeldurchmesser: 20,0 mm

Materialstärke: 12,0 mm

Matrizenöffnung: 21,2 mm

=> Falls in der Bestellung keine Matrizenabmessungen oder Materialstärken mitgeteilt werden, so wird generell das Schneidspiel 0,7 mm geliefert.

Für Langlochschnittform:

Langlochwerkzeuge werden nach der Mubea-Norm mit 0,3 mm und 1,0 mm Schneidspiel gefertigt.

Materialstärke: mm	bis 6	> 6 bis 14
Schneidspiel: mm	0,3	1,0

Beispiel: Langlochabmessung: 11,0 x 30,0 mm

Materialstärke: 1 – 6 mm

= Matrizenöffnung: 11,3 x 30,3 mm

Materialstärke: 6 – 14 mm

= Matrizenöffnung: 12,0 x 31,0 mm

=> Falls in der Bestellung keine Matrizenabmessungen oder Materialstärken mitgeteilt werden, so wird generell das Schneidspiel 1,0 mm geliefert.

Auf Wunsch werden die hier aufgeführten Stempel und Matrizenarten als Sonderanfertigung in jeder gewünschten Schnittform hergestellt; z. B. Dreieck-, Rechteck-, Sechskant- sowie in anderen Schnittformen. Die gängigsten Sonderformen wurden bereits genormt und in diesen Katalog aufgenommen.

Bei Langloch, Rechteck oder ähnlichen Werkzeugen über 50 mm Schnittbereich (Sonderanfertigung, nicht genormt) ist anzugeben, ob das Stanzloch längs oder quer zur Maschine stehen soll (siehe Abbildung).

Selbstverständlich können alle Spezialstanzwerkzeuge nach Ihren Angaben (Zeichnung oder Muster) gefertigt werden.

Bitte beachten Sie beim Einsatz von unseren Stanzwerkzeugen folgende grundlegende Punkte:

- Achten Sie bitte auf einen gleichmäßigen Schneidspalt zwischen Stempel- und Matrizenöffnung.
- Die Matrize muss in der Halterung einen festen Sitz haben. Ebenfalls müssen Stempelhalter und Stempelfutter in ihren Halterungen sicher befestigt sein.
- Die Abstreifer / Niederhalter (siehe nachstehende Skizze) müssen gleichmäßig abstreifen und plan zur Matrizenoberfläche stehen.
- Um eine möglichst lange Lebensdauer der Werkzeuge zu erreichen, sollten die Stempel beim Stanzen öfter mit Öl bestrichen werden.
- Beim Einsatz von Langloch, Viereck sowie in anderen Spezial-Schnittformen muss der mitgelieferte Verdrehsicherungsstift eingesetzt werden.
- Um eine Überlastung Ihrer Maschine zu vermeiden, empfehlen wir, den beim Stanzen der Löcher entstehenden Stanzdruck nach folgender Formel zu überprüfen. Die max. Stanzkraft ist aus dem Leistungsschild an Ihrer Maschine ersichtlich.

$$\text{Stanzkraft } F = \frac{\text{Umfang Stempel } (\pi * d) * \text{Materialstärke } (s) * \text{Zugfestigkeit } (R_m) * 0,8}{9810 \text{ (Umrechnung Nm in t)}}$$

R_m = Zugfestigkeit (N/mm²):
 Edelstahl 1.4301 = 720 N/mm²
 Stahl St-37 = 450 N/mm²
 Aluminium AlMg3 = 220 N/mm²

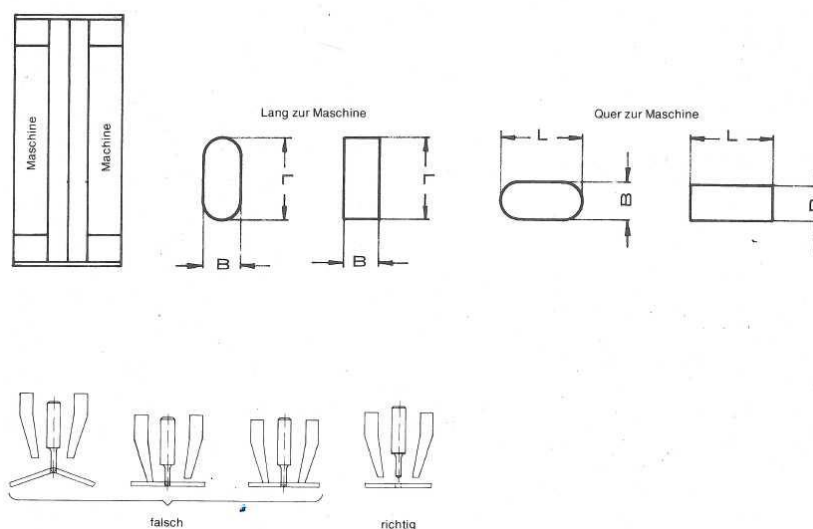

Rundstempel Nr. 1 Code 50505 1 1

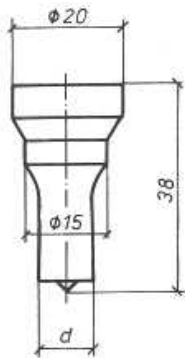

Abmessungen
3,0
3,5
4,0
4,5
5,0
5,5
6,0
6,5
7,0
7,5
8,0
8,5
9,0
9,5
10,0
10,5
11,0
11,5
12,0
12,5
13,0
13,5
14,0
14,5
15,0

Nur einsetzbar mit Reduzierung 50531 und Stempelbeilage 50529

Rundstempel Nr. 2 Code 50505 2 1

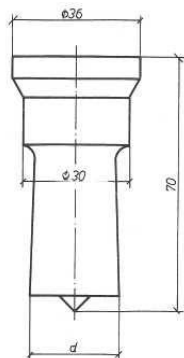

Abmessungen	
12,0	22,0
13,0	22,5
14,0	23,0
15,0	23,5
15,5	24,0
16,0	24,5
16,5	25,0
17,0	25,5
17,5	26,0
18,0	26,5
18,5	27,0
19,0	27,5
19,5	28,0
20,0	28,5
20,5	29,0
21,0	29,5
21,5	30,0

Bei einigen Modellen nur einsetzbar mit Reduzierung 50531 5 (siehe Kapitel 2).

Rundstempel Nr. 3 Code 50505 3 1

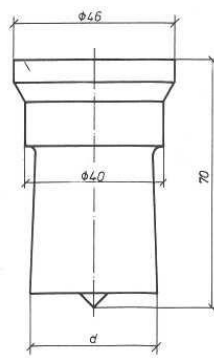

Abmessungen
30,5
31,0
31,5
32,0
32,5
33,0
33,5
34,0
34,5
35,0
35,5
36,0
36,5
37,0
37,5
38,0
38,5
39,0
39,5
40,0

Bei einigen Modellen nur einsetzbar mit Sonderstanz-einrichtung.

Rundstempel Nr. 4 Code 50505 4 1

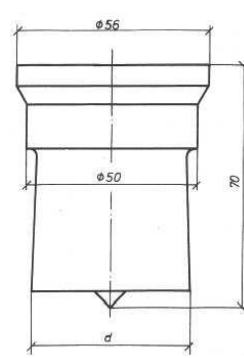

Abmessungen
40,5
41,0
41,5
42,0
42,5
43,0
43,5
44,0
44,5
45,0
45,5
46,0
46,5
47,0
47,5
48,0
48,5
49,0
49,5
50,0

Einsetzbar nur mit Sonderstanz-einrichtung

Vierkantstempel Nr. 2
Code 50505 2 2

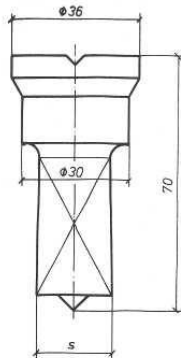

Abmessungen	
4,0	13,0
4,5	13,5
5,0	14,0
5,5	14,5
6,0	15,0
6,5	15,5
7,0	16,0
7,5	16,5
8,0	17,0
8,5	17,5
9,0	18,0
9,5	18,5
10,0	19,0
10,5	19,5
11,0	20,0
11,5	20,5
12,0	21,0
12,5	

Bei einigen Modellen nur einsetzbar mit Reduzierung 50531 5 (siehe Kapitel 2).

Vierkantstempel Nr. 3
Code 50505 3 2

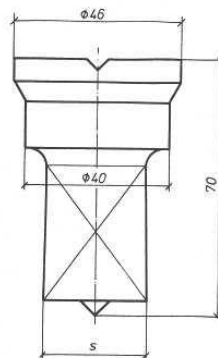

Abmessungen
21,5
22,0
22,5
23,0
23,5
24,0
24,5
25,0
25,5
26,0
26,5
27,0
27,5
28,0

Einsetzbar bei einigen Modellen nur mit Sonderstanzeinrichtung.

Vierkantstempel Nr. 4
Code 50505 4 2

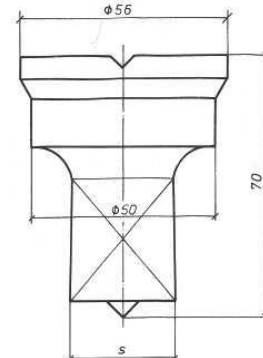

Abmessungen
28,5
29,0
29,5
30,0
30,5
31,0
31,5
32,0
32,5
33,0
33,5
34,0
34,5
35,0

Einsetzbar nur mit Sonderstanzeinrichtung.

Langlochstempel Nr. 2
Code 50505 2 3

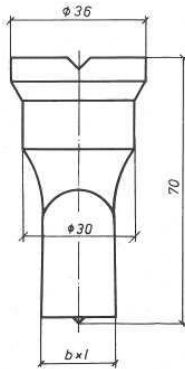

Abmessungen		
5,0 x 10,0	8,0 x 30,0	13,0 x 20,0
5,0 x 13,0	9,0 x 13,0	13,0 x 25,0
5,0 x 15,0	9,0 x 18,0	13,0 x 30,0
5,0 x 20,0	9,0 x 20,0	13,5 x 20,0
5,0 x 25,0	9,0 x 25,0	13,5 x 25,0
5,5 x 11,0	9,0 x 30,0	13,5 x 30,0
5,5 x 13,0	9,5 x 13,0	14,0 x 20,0
5,5 x 15,0	9,5 x 15,0	14,0 x 25,0
5,5 x 20,0	9,5 x 20,0	14,0 x 30,0
5,5 x 25,0	9,5 x 25,0	16,0 x 25,0
6,5 x 13,0	9,5 x 30,0	16,0 x 30,0
6,5 x 15,0	10,5 x 15,0	17,5 x 25,0
6,5 x 20,0	10,5 x 21,0	17,5 x 30,0
6,5 x 25,0	10,5 x 25,0	18,0 x 30,0
6,5 x 30,0	10,5 x 30,0	19,0 x 25,0
7,0 x 15,0	11,0 x 15,0	19,0 x 30,0
7,0 x 20,0	11,0 x 20,0	20,5 x 25,0
7,0 x 25,0	11,0 x 25,0	20,5 x 30,0
7,0 x 30,0	11,0 x 30,0	22,0 x 30,0
8,0 x 13,0	12,0 x 20,0	22,5 x 30,0
8,0 x 16,0	12,0 x 25,0	24,0 x 30,0
8,0 x 20,0	12,0 x 30,0	25,5 x 30,0
8,0 x 25,0		

Bei einigen Modellen nur einsetzbar mit Reduzierung 50531 5 (siehe Kapitel 2),

Langlochstempel Nr. 3
Code 50505 3 3

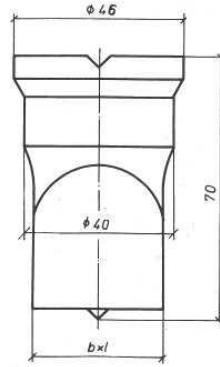

Abmessungen
9,0 x 40,0
11,0 x 35,0
11,0 x 40,0
13,5 x 35,0
13,5 x 40,0
14,0 x 35,0
14,0 x 40,0
16,0 x 35,0
16,0 x 40,0
17,5 x 35,0
17,5 x 40,0
19,0 x 35,0
19,0 x 40,0
20,5 x 35,0
20,5 x 40,0
22,5 x 35,0
22,5 x 40,0
24,0 x 40,0
25,5 x 40,0
26,0 x 40,0
27,0 x 40,0

Bei einigen Modellen nur einsetzbar mit Sonderstanzeinrichtung

Langlochstempel Nr. 4
Code 50505 4 3

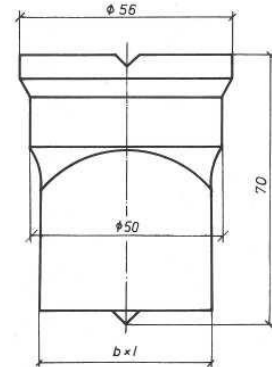

Abmessungen
11,0 x 45,0
11,0 x 50,0
13,5 x 50,0
17,5 x 50,0
20,5 x 50,0
22,5 x 50,0
24,0 x 50,0
25,5 x 50,0
26,0 x 50,0
27,0 x 50,0

Einsetzbar nur mit Sonderstanzeinrichtung.

**Rundstempel Nr. 50N
Code 50585 1 1**

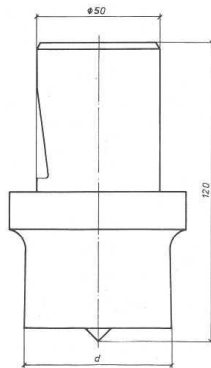

Abmessungen	
50,5	62,0
51,0	62,5
51,5	63,0
52,0	63,5
52,5	64,0
53,0	64,5
53,5	65,0
54,0	65,5
54,5	66,0
55,0	66,5
55,5	67,0
56,0	67,5
56,5	68,0
57,0	68,5
57,5	69,0
58,0	69,5
58,5	70,0
59,0	
59,5	
60,0	
60,5	
61,0	
61,5	

**Rundstempel Nr. 50N
Code 50585 2 1**

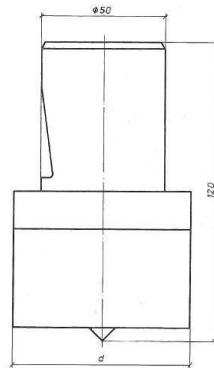

Abmessungen		
70,5	80,5	90,5
71,0	81,0	91,0
71,5	81,5	91,5
72,0	82,0	92,0
72,5	82,5	92,5
73,0	83,0	93,0
73,5	83,5	93,5
74,0	84,0	94,0
74,5	84,5	94,5
75,0	85,0	95,0
75,5	85,5	95,5
76,0	86,0	96,0
76,5	86,5	96,5
77,0	87,0	97,0
77,5	87,5	97,5
78,0	88,0	98,0
78,5	88,5	98,5
79,0	89,0	99,0
79,5	89,5	99,5
80,0	90,0	100,0

**Rundstempel Nr. 50N
Code 50585 3 1**

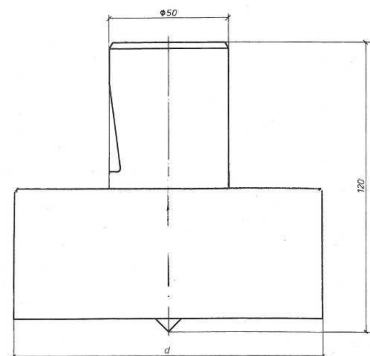

Abmessungen
105,0
110,0
115,0
120,0
125,0
130,0
135,0
140,0
145,0
150,0

Vierkantstempel Nr. 50N
Code 50586 1 2

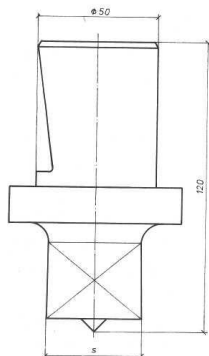

Abmessungen
40,0
42,0
45,0
50,0

Vierkantstempel Nr. 50N
Code 50586 2 2

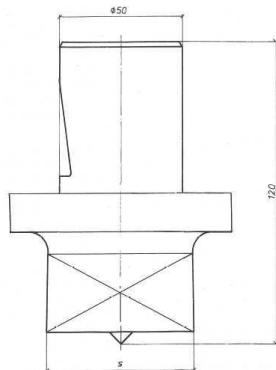

Abmessungen
55,0
60,0

Vierkantstempel Nr. 50N
Code 50586 3 2

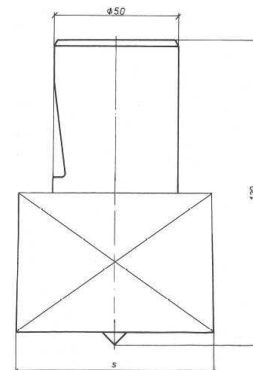

Abmessungen
65,0
70,0

Rundstempel Nr. 15N
Code 50516 1 1

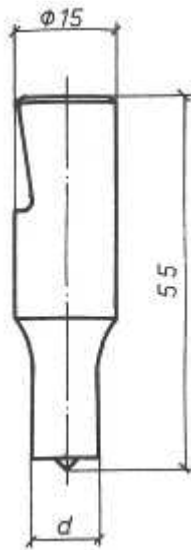

Abmessungen
3,0
3,5
4,0
4,5
5,0
5,5
6,0
6,5
7,0
7,5
8,0
8,5
9,0
9,5
10,0
10,5
11,0
11,5
12,0
12,5
13,0
13,5
14,0
14,5
15,0

Vierkantstempel Nr. 15N
Code 50516 1 2

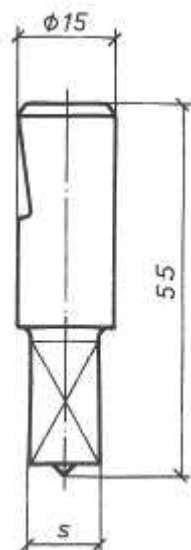

Abmessungen
4,0
4,5
5,0
5,5
6,0
6,5
7,0
7,5
8,0
8,5
9,0
9,5
10,0
10,5

Langlochstempel Nr. 15N
Code 50516 1 3

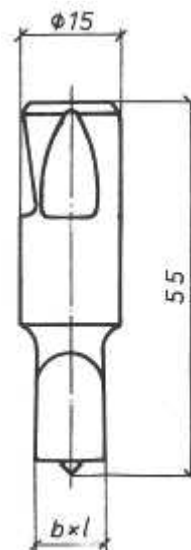

Abmessungen
5,0 x 10,0
5,0 x 13,0
5,0 x 15,0
5,5 x 11,0
5,5 x 13,0
5,5 x 15,0
6,5 x 13,0
6,5 x 15,0
7,0 x 15,0
8,0 x 13,0
9,0 x 13,0
9,5 x 13,0
9,5 x 15,0
10,5 x 15,0
11,0 x 15,0

Rundstempel Nr. 15N
Code 50525 0 1

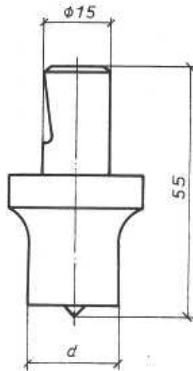

Abmessungen
15,5
16,0
16,5
17,0
17,5
18,0
18,5
19,0
19,5
20,0
20,5
21,0
21,5
22,0
22,5
23,0
23,5
24,0
24,5
25,0
25,5
26,0
26,5
27,0
27,5
28,0
28,5
29,0
29,5
30,0

Vierkantstempel Nr. 15N
Code 50525 0 2

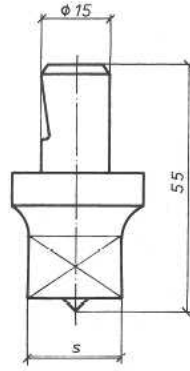

Abmessungen
11,0
11,5
12,0
12,5
13,0
13,5
14,0
14,5
15,0
15,5
16,0
16,5
17,0
27,5
18,0
18,5
19,0
19,5
20,0
20,5
21,0

Langlochstempel Nr. 15N
Code 50525 0 3

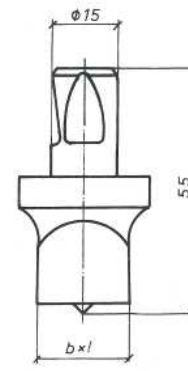

Abmessungen	Abmessungen
5,0 x 20,0	11,0 x 25,0
5,0 x 25,0	11,0 x 30,0
5,5 x 20,0	12,0 x 20,0
5,5 x 25,0	12,0 x 25,0
6,5 x 20,0	12,0 x 30,0
6,5 x 25,0	13,0 x 20,0
6,5 x 30,0	13,0 x 25,0
7,0 x 20,0	13,0 x 30,0
7,0 x 25,0	13,5 x 20,0
7,0 x 30,0	13,5 x 25,0
8,0 x 16,0	13,5 x 30,0
8,0 x 20,0	14,0 x 20,0
8,0 x 25,0	14,0 x 25,0
8,0 x 30,0	14,0 x 30,0
9,0 x 18,0	16,0 x 25,0
9,0 x 20,0	16,0 x 30,0
9,0 x 25,0	17,5 x 25,0
9,0 x 30,0	17,5 x 30,0
9,5 x 20,0	19,0 x 25,0
9,5 x 25,0	19,0 x 30,0
9,5 x 30,0	20,5 x 25,0
10,5 x 21,0	20,5 x 30,0
10,5 x 25,0	22,5 x 30,0
10,5 x 30,0	24,0 x 30,0
11,0 x 20,0	25,5 x 30,0

Rundstempel Nr. 35
Code 50509 2 1



Abmessungen	
5,0	18,0
5,5	18,5
6,0	19,0
6,5	19,5
7,0	20,0
7,5	20,5
8,0	21,0
8,5	21,5
9,0	22,0
9,5	22,5
10,0	23,0
10,5	23,5
11,0	24,0
11,5	24,5
12,0	25,0
12,5	25,5
13,0	26,0
13,5	26,5
14,0	27,0
14,5	27,5
15,0	28,0
15,5	28,5
16,0	29,0
16,5	29,5
17,0	30,0
17,5	

Vierkantstempel Nr. 35
Code 50509 2 2

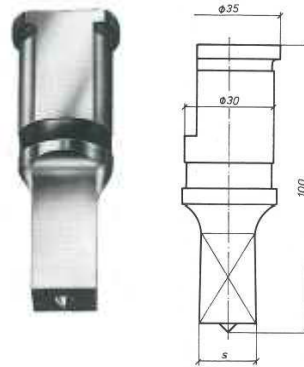

Abmessungen	
5,0	13,5
5,5	14,0
6,0	14,5
6,5	15,0
7,0	15,5
7,5	16,0
8,0	16,5
8,5	17,0
9,0	17,5
9,5	18,0
10,0	18,5
10,5	19,0
11,0	19,5
11,5	20,0
12,0	20,5
12,5	21,0
13,0	

Rundmatrize Nr. 30
Code 50633 0 1

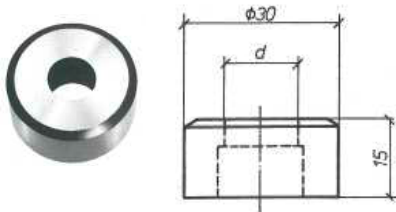

Abmessungen
3,2
3,7
4,2
4,7
5,2
5,7
6,2
6,7
7,2
7,7
8,2
8,7
9,2
9,7
10,2
10,7
11,2
11,7
12,2
12,7
13,2
13,7
14,2
14,7
15,2
15,7
16,2

Einsetzbar nur mit Matrizenhalter 50606
(siehe Kapitel 2)

Vierkantmatrize Nr. 30
Code 50633 0 2

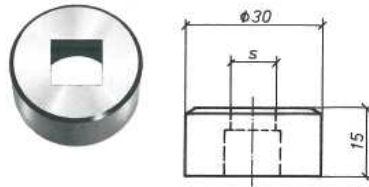

Abmessungen
4,2
4,7
5,2
5,7
6,2
6,7
7,2
7,7
8,2
8,7
9,2
9,7
10,2
10,7
11,2

Einsetzbar nur mit Matrizenhalter 50606
(siehe Kapitel 2)

Langlochmatrize Nr. 30
Code 50633 0 3

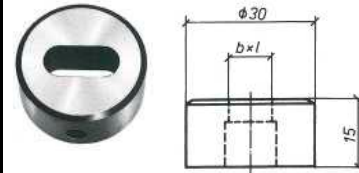

Abmessungen
5,3 x 10,3
5,3 x 13,3
5,3 x 15,3
5,8 x 11,3
5,8 x 13,3
5,8 x 15,3
6,0 x 11,0
6,0 x 14,0
6,0 x 16,0
6,5 x 12,0
6,5 x 14,0
6,5 x 16,0
6,8 x 13,3
6,8 x 15,3
7,3 x 15,3
7,5 x 14,0
7,5 x 16,0
8,0 x 16,0
8,3 x 13,3
9,0 x 14,0
9,3 x 13,3
9,8 x 13,3
9,8 x 15,3
10,0 x 14,0
10,5 x 14,0
10,5 x 16,0
10,8 x 15,3
11,3 x 15,3
11,5 x 16,0
12,0 x 16,0

Einsetzbar nur mit Matrizenhalter 50606
(siehe Kapitel 2)

Rundmatrize Nr. 45
Code 50638 0 1

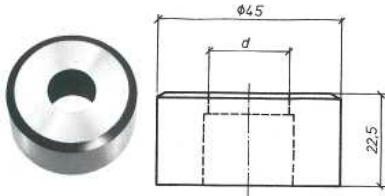

Abmessungen	
12,7	22,7
13,2	23,2
13,7	23,7
14,2	24,2
14,7	24,7
15,2	25,2
15,7	25,7
16,2	26,2
16,7	26,7
17,2	27,2
17,7	27,7
18,2	28,2
18,7	28,7
19,2	29,2
19,7	29,7
20,2	30,2
20,7	30,7
21,2	31,2
21,7	31,7
22,2	

Bei einigen Modellen nur einsetzbar mit Matrizenhalter 50606 3 (siehe Kapitel 2).

Vierkantmatrize Nr. 45
Code 50638 0 2

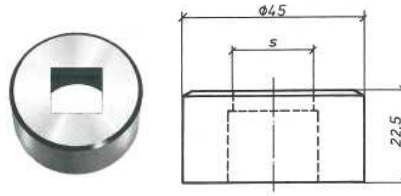

Abmessungen
11,7
12,2
12,7
13,2
13,7
14,2
14,7
15,2
15,7
16,2
16,7
17,2
17,7
18,2
18,7
19,2
19,7
20,2
20,7
21,2
21,7
22,2
22,7

Bei einigen Modellen nur einsetzbar mit Matrizenhalter 50606 3 (siehe Kapitel 2).

Langlochmatrize Nr. 45
Code 50638 0 3

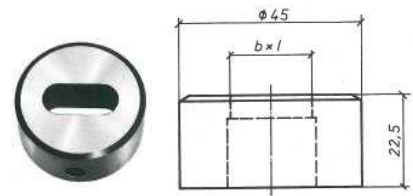

Abmessungen		
5,3 x 20,3	10,0 x 19,0	14,5 x 26,0
5,3 x 25,3	10,0 x 21,0	14,5 x 31,0
5,8 x 20,3	10,0 x 26,0	14,3 x 20,3
5,8 x 25,3	10,0 x 31,0	14,3 x 25,3
6,0 x 21,0	10,5 x 26,0	14,3 x 30,3
6,0 x 26,0	10,5 x 31,0	15,0 x 21,0
6,5 x 21,0	10,5 x 21,0	15,0 x 26,0
6,5 x 26,0	10,8 x 21,3	15,0 x 31,0
6,8 x 20,3	10,8 x 25,3	16,3 x 25,3
6,8 x 25,3	10,8 x 30,3	16,3 x 30,3
6,8 x 30,3	11,5 x 22,0	17,0 x 26,0
7,5 x 21,0	11,5 x 26,0	17,0 x 31,0
7,5 x 26,0	11,5 x 31,0	17,8 x 25,3
7,5 x 31,0	11,3 x 20,3	17,8 x 30,3
7,3 x 20,3	11,3 x 25,3	18,3 x 30,3
7,3 x 25,3	11,3 x 30,3	18,5 x 26,0
7,3 x 30,3	12,0 x 21,0	18,5 x 31,0
8,0 x 21,0	12,0 x 26,0	19,0 x 31,0
8,0 x 26,0	12,0 x 31,0	19,3 x 25,3
8,0 x 31,0	12,3 x 20,3	19,3 x 30,3
8,3 x 16,3	12,3 x 25,3	20,0 x 26,0
8,3 x 20,3	12,3 x 30,3	20,0 x 31,0
8,3 x 25,3	13,0 x 21,0	20,8 x 25,3
8,3 x 30,3	13,0 x 26,0	20,8 x 30,3
9,0 x 17,0	13,0 x 31,0	21,5 x 26,0
9,0 x 21,0	13,3 x 20,3	21,5 x 31,0
9,0 x 26,0	13,3 x 25,3	22,3 x 30,3
9,0 x 31,0	13,3 x 30,3	22,8 x 30,3
9,3 x 18,3	13,8 x 20,3	23,0 x 31,0
9,3 x 20,3	13,8 x 25,3	23,5 x 31,0
9,3 x 25,3	13,8 x 30,3	24,3 x 30,3
9,3 x 30,3	14,0 x 21,0	25,0 x 31,0
9,8 x 20,3	14,0 x 26,0	25,8 x 30,3
9,8 x 25,3	14,0 x 31,0	26,5 x 31,0
9,8 x 30,3	14,5 x 21,0	

Rundmatrize Nr. 60
Code 50639 0 1

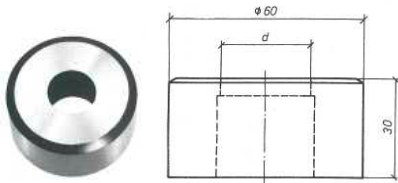

Abmessungen
30,7
31,2
31,7
32,2
32,7
33,2
33,7
34,2
34,7
35,2
35,7
36,2
36,7
37,2
27,7
38,2
38,7
39,2
39,7
40,2
40,7
41,2
41,7
42,2

Bei einigen Modellen nur einsetzbar mit Sonderstanzeinrichtung.

Vierkantmatrize Nr. 60
Code 50639 0 2

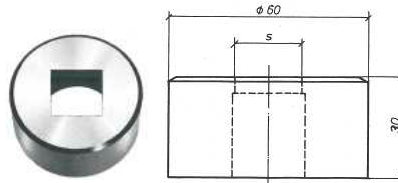

Abmessungen
21,7
22,2
22,7
23,2
23,7
24,2
24,7
25,2
25,7
26,2
26,7
27,2
27,7
28,2
28,7
29,2

Bei einigen Modellen nur einsetzbar mit Sonderstanzeinrichtung.

Langlochmatrize Nr. 60 Code
50639 0 3

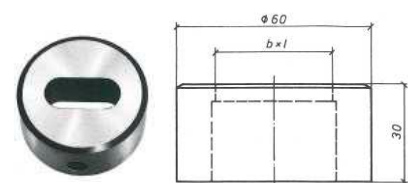

Abmessungen	
9,3 x 40,3	20,8 x 35,3
10,0 x 41,0	20,8 x 40,3
11,3 x 35,3	21,5 x 36,0
11,3 x 40,3	21,5 x 41,0
12,0 x 36,0	22,8 x 35,3
12,0 x 41,0	22,8 x 40,3
13,8 x 35,3	23,5 x 36,0
13,8 x 40,3	23,5 x 41,0
14,3 x 35,3	24,3 x 40,3
14,3 x 40,3	25,0 x 41,0
14,5 x 36,0	25,8 x 40,3
14,5 x 41,0	26,3 x 40,3
15,0 x 36,0	26,5 x 41,0
15,0 x 41,0	27,0 x 41,0
16,3 x 35,3	27,3 x 40,3
16,3 x 40,3	28,0 x 41,0
17,0 x 36,0	
17,0 x 41,0	
17,8 x 35,3	
17,8 x 40,3	
18,5 x 36,0	
18,5 x 41,0	
19,3 x 35,3	
19,3 x 40,3	
20,0 x 36,0	
20,0 x 41,0	

Bei einigen Modellen nur einsetzbar mit Sonderstanzeinrichtung.

Rundmatrize Nr. 80
Code 50640 0 1

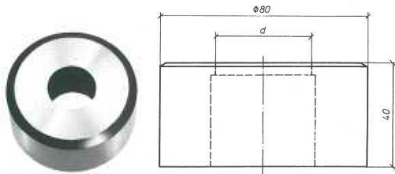

Abmessungen
40,7
41,2
41,7
42,2
42,7
43,2
43,7
44,2
44,7
45,2
45,7
46,2
46,7
47,2
47,7
48,2
48,7
49,2
49,7
50,2
50,7
51,2

Einsetzbar nur mit Sonderstanzeinrichtung

Vierkantmatrize Nr. 80
Code 50640 0 2

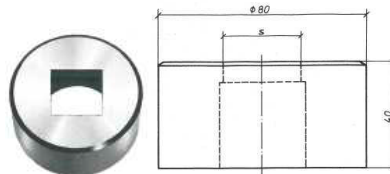

Abmessungen
28,7
29,2
29,7
30,2
30,7
31,2
31,7
32,2
32,7
33,2
33,7
34,2
34,7
35,2
35,7

Einsetzbar nur mit Sonderstanzeinrichtung

Langlochmatrize Nr. 80
Code 50640 0 3

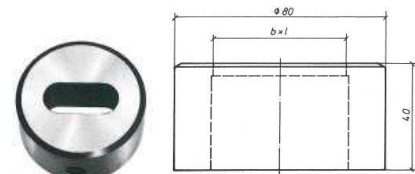

Abmessungen
11,3 x 45,3
11,3 x 50,3
12,0 x 46,0
12,0 x 51,0
13,8 x 50,3
14,5 x 51,0
17,8 x 50,3
18,5 x 51,0
20,8 x 50,3
21,5 x 51,0
22,8 x 50,3
23,5 x 51,0
24,3 x 50,3
25,0 x 51,0
25,8 x 50,3
26,3 x 50,3
26,5 x 51,0
27,0 x 51,0
27,3 x 50,3
28,0 x 51,0

Einsetzbar nur mit Sonderstanzeinrichtung

Rundmatrize Nr. 150
Code 50658 1 1

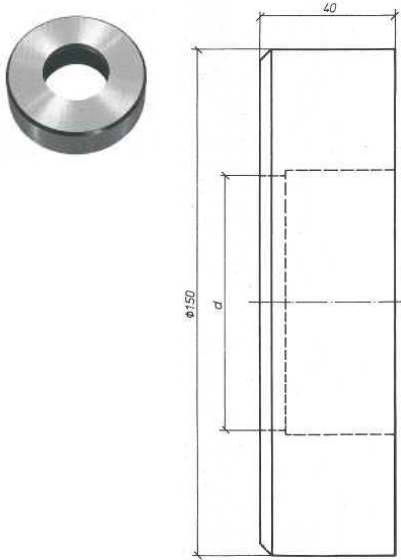

Abmessungen			
50,7	63,7	76,7	89,7
51,2	64,2	77,2	90,2
51,7	64,7	77,7	90,7
52,2	65,2	78,2	91,2
52,7	65,7	78,7	91,2
53,2	66,2	79,2	92,2
53,7	66,7	79,7	92,7
54,2	67,2	80,2	93,2
54,7	67,7	80,7	93,7
55,2	68,2	81,2	94,2
55,7	68,7	81,7	94,7
56,2	69,2	82,2	95,2
56,7	69,7	82,7	95,7
57,2	70,2	83,2	96,2
57,7	70,7	83,7	96,7
58,2	71,2	84,2	97,2
58,7	71,7	84,7	97,7
59,2	72,2	85,2	98,2
59,7	72,7	85,7	98,7
60,2	73,2	86,2	99,2
60,7	73,7	86,7	99,7
61,2	74,2	87,2	100,2
61,7	74,7	87,7	100,7
62,2	75,2	88,2	
62,7	75,7	88,7	
63,2	76,2	89,2	

Rundmatrize Nr. 200
Code 50658 2 1

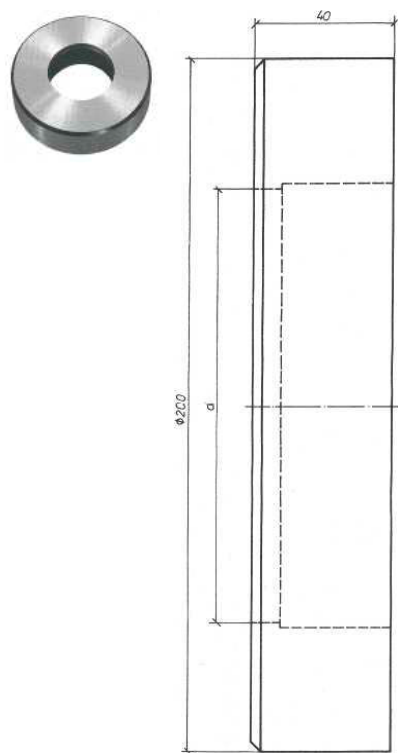

Abmessungen
105,3
110,3
115,3
120,3
125,3
130,3
135,3
140,3
145,3
150,3

Vierkantmatrize Nr. 150
Code 50658 1 2

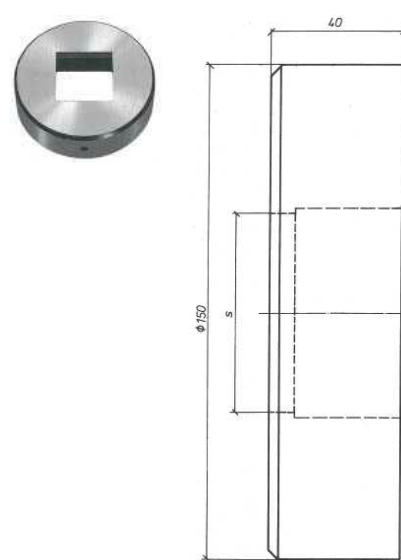

Abmessungen
40,3
45,3
50,3
55,3
60,3
65,3
70,3

Exzenter-Matrize Nr. 45E
Code 50653 1 1

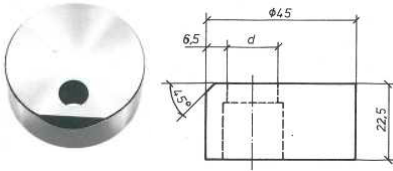

Abmessungen	
3,2	16,7
3,7	17,2
4,2	17,7
4,7	18,2
5,2	18,7
5,7	19,2
6,2	19,7
6,7	20,2
7,2	20,7
7,7	21,2
8,2	21,7
8,7	22,2
9,2	22,7
9,7	23,2
10,2	23,7
10,7	24,2
11,2	24,7
11,7	25,2
12,2	25,7
12,7	26,2
13,2	26,7
13,7	27,2
14,2	27,7
14,7	28,2
15,2	28,7
15,7	29,2
16,2	29,7

Zum Stanzen von L-Profilen DIN 1028 und
DIN 1029, Z-Profilen DIN 1027, T-Profilen DIN
1024, IPE-Profilen DIN 1025 Bl., 5
Bei einigen Modellen nur einsetzbar mit
Matrizenhalter 50654

Exzenter-Matrize Nr. 45E-2
Code 50653 2 1

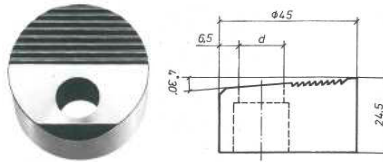

Abmessungen	
7,2	18,7
7,7	19,2
8,2	19,7
8,7	20,2
9,2	20,7
9,7	21,2
10,2	21,7
10,7	22,2
11,2	22,7
11,7	23,2
12,2	23,7
12,7	24,2
13,2	24,7
13,7	25,2
14,2	25,7
14,7	26,2
15,2	26,7
15,7	27,2
16,2	27,7
16,7	28,2
17,2	28,7
17,7	29,2
18,2	29,7

Zum Stanzen von U-Profilen nach DIN 1026
Bei einigen Modellen nur einsetzbar mit
Matrizenhalter 50654

Exzenter-Matrize Nr. 45E-3
Code 50653 3 1

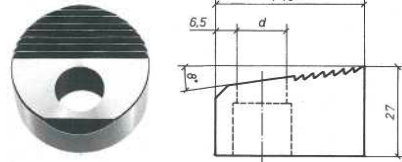

Abmessungen	
6,2	18,2
6,7	18,7
7,2	19,2
7,7	19,7
8,2	20,2
8,7	20,7
9,2	21,2
9,7	21,7
10,2	22,2
10,7	22,7
11,2	23,2
11,7	23,7
12,2	24,2
12,7	24,7
13,2	25,2
13,7	25,7
14,2	26,2
14,7	26,7
15,2	27,2
15,7	27,7
16,2	28,2
16,7	28,7
17,2	29,2
17,7	29,7

Zum Stanzen von I-Profilen nach DIN 1025 Bl.
1
Bei einigen Modellen nur einsetzbar mit
Matrizenhalter 50654

Exzenter-Matrize Nr. 45E-3 quer
Code 50679 1 3

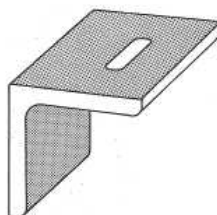
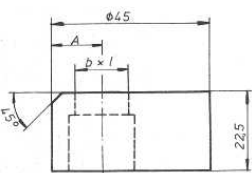

Abmessung	A	Abmessung	A	Abmessung	A	Abmessung	A
5,3 x 10,3	9,5	8,0 x 16,0	11,5	10,8 x 15,3	12,5	14,5 x 21,0	14,5
5,3 x 13,3	9,5	8,0 x 21,0	12,5	10,8 x 21,3	13,5	14,5 x 26,0	16,0
5,3 x 15,3	10,5	8,0 x 26,0	15,0	10,8 x 25,3	15,0	14,5 x 31,0	20,0
5,3 x 20,3	11,5	8,0 x 31,0	19,5	10,8 x 30,3	18,5	15,0 x 21,0	15,0
5,3 x 25,3	13,5	8,3 x 13,3	11,0	11,3 x 15,3	12,5	15,0 x 26,0	16,5
5,8 x 11,3	10,0	8,3 x 16,3	11,5	11,3 x 20,3	13,5	15,0 x 31,0	20,0
5,8 x 13,3	10,0	8,3 x 20,3	12,5	11,3 x 25,3	15,0	16,3 x 25,3	16,5
5,8 x 15,3	10,0	8,3 x 25,3	14,5	11,3 x 30,3	18,5	16,3 x 30,3	19,0
5,8 x 20,3	12,0	8,3 x 30,3	18,5	11,5 x 16,0	12,5	17,0 x 26,0	16,5
5,8 x 25,3	14,0	9,0 x 14,0	11,5	11,5 x 22,0	14,0	17,0 x 31,0	20,0
6,0 x 11,0	10,0	9,0 x 17,0	12,0	11,5 x 26,0	15,5	17,8 x 25,3	17,0
6,0 x 14,0	10,5	9,0 x 21,0	13,0	11,5 x 31,0	19,5	17,8 x 30,3	20,0
6,0 x 16,0	10,5	9,0 x 26,0	15,0	12,0 x 16,0	13,0	18,3 x 30,3	20,0
6,0 x 21,0	11,0	9,0 x 31,0	19,5	12,0 x 21,0	14,0	18,5 x 26,0	17,0
6,0 x 26,0	14,5	9,3 x 13,3	11,5	12,0 x 26,0	15,5	18,5 x 31,0	20,0
6,5 x 12,0	10,5	9,3 x 18,3	12,5	12,0 x 31,0	19,5	19,0 x 31,0	20,0
6,5 x 14,0	10,5	9,3 x 20,3	13,0	12,3 x 20,3	13,5	19,3 x 25,3	17,0
6,5 x 16,0	11,0	9,3 x 25,3	14,5	12,3 x 25,3	15,5	19,3 x 30,3	20,0
6,5 x 21,0	12,5	9,3 x 30,3	18,5	12,3 x 30,3	18,5	20,0 x 26,0	17,5
6,5 x 26,0	15,0	9,8 x 13,3	12,0	13,0 x 21,0	14,0	20,0 x 31,0	20,5
6,8 x 13,3	10,5	9,8 x 15,3	12,0	13,0 x 26,0	16,0	20,8 x 25,3	17,5
6,8 x 15,3	11,0	9,8 x 20,3	13,0	13,0 x 31,0	19,0	20,8 x 30,3	20,0
6,8 x 20,3	12,0	9,8 x 25,3	15,0	13,3 x 20,3	14,0	21,5 x 26,0	18,0
6,8 x 25,3	14,0	9,8 x 30,3	18,5	13,3 x 25,3	15,5	21,5 x 31,0	20,5
6,8 x 30,3	18,0	10,0 x 14,0	12,0	13,3 x 30,3	19,0	22,3 x 30,3	20,0
7,3 x 15,3	11,0	10,0 x 19,0	12,5	13,8 x 20,3	14,0	22,8 x 30,3	20,0
7,3 x 20,3	12,0	10,0 x 21,0	13,0	13,8 x 25,3	16,0	23,0 x 31,0	20,5
7,3 x 25,3	14,5	10,0 x 26,0	15,0	13,8 x 30,3	19,0	23,5 x 31,0	20,5
7,3 x 30,3	18,0	10,0 x 31,0	19,5	14,0 x 21,0	14,5	24,3 x 30,3	20,5
7,5 x 14,0	11,0	10,5 x 14,0	12,0	14,0 x 26,0	16,0	25,0 x 31,0	21,0
7,5 x 16,0	11,5	10,5 x 16,0	12,5	14,0 x 31,0	20,0	25,8 x 30,3	20,5
7,5 x 21,0	12,5	10,5 x 21,0	13,5	14,3 x 20,3	14,5	26,5 x 31,0	21,0
7,5 x 26,0	14,5	10,5 x 26,0	15,5	14,3 x 25,3	16,0		
7,5 x 31,0	19,0	10,5 x 31,0	19,5	14,3 x 30,3	19,0		

Zum Stanzen von L-Profilen nach DIN 1028 und DIN 1029, Z-Profilen DIN 1027, T-Profilen DIN 1024, IPE-Profilen DIN 1025 Bl., 5
Bei einigen Modellen nur einsetzbar mit Matrizenhalter 50654

Exzenter-Matrize Nr. 45E-3 längs
Code 50680 1 3

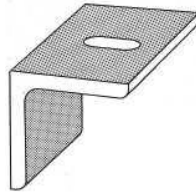
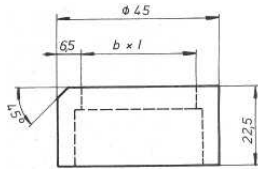

Abmessung	Abmessung	Abmessung	Abmessung
5,3 x 10,3	8,0 x 16,0	10,8 x 15,3	14,5 x 21,0
5,3 x 13,3	8,0 x 21,0	10,8 x 21,3	14,5 x 26,0
5,3 x 15,3	8,0 x 26,0	10,8 x 25,3	14,5 x 31,0
5,3 x 20,3	8,0 x 31,0	10,8 x 30,3	15,0 x 21,0
5,3 x 25,3	8,3 x 13,3	11,3 x 15,3	15,0 x 26,0
5,8 x 11,3	8,3 x 16,3	11,3 x 20,3	15,0 x 31,0
5,8 x 13,3	8,3 x 20,3	11,3 x 25,3	16,3 x 25,3
5,8 x 15,3	8,3 x 25,3	11,3 x 30,3	16,3 x 30,3
5,8 x 20,3	8,3 x 30,3	11,5 x 16,0	17,0 x 26,0
5,8 x 25,3	9,0 x 14,0	11,5 x 22,0	17,0 x 31,0
6,0 x 11,0	9,0 x 17,0	11,5 x 26,0	17,8 x 25,3
6,0 x 14,0	9,0 x 21,0	11,5 x 31,0	17,8 x 30,3
6,0 x 16,0	9,0 x 26,0	12,0 x 16,0	18,3 x 30,3
6,0 x 21,0	9,0 x 31,0	12,0 x 21,0	18,5 x 26,0
6,0 x 26,0	9,3 x 13,3	12,0 x 26,0	18,5 x 31,0
6,5 x 12,0	9,3 x 18,3	12,0 x 31,0	19,0 x 31,0
6,5 x 14,0	9,3 x 20,3	12,3 x 20,3	19,3 x 25,3
6,5 x 16,0	9,3 x 25,3	12,3 x 25,3	19,3 x 30,3
6,5 x 21,0	9,3 x 30,3	12,3 x 30,3	20,0 x 26,0
6,5 x 26,0	9,8 x 13,3	13,0 x 21,0	20,0 x 31,0
6,8 x 13,3	9,8 x 15,3	13,0 x 26,0	20,8 x 25,3
6,8 x 15,3	9,8 x 20,3	13,0 x 31,0	20,8 x 30,3
6,8 x 20,3	9,8 x 25,3	13,3 x 20,3	21,5 x 26,0
6,8 x 25,3	9,8 x 30,3	13,3 x 25,3	21,5 x 31,0
6,8 x 30,3	10,0 x 14,0	13,3 x 30,3	22,3 x 30,3
7,3 x 15,3	10,0 x 19,0	13,8 x 20,3	22,8 x 30,3
7,3 x 20,3	10,0 x 21,0	13,8 x 25,3	23,0 x 31,0
7,3 x 25,3	10,0 x 26,0	13,8 x 30,3	23,5 x 31,0
7,3 x 30,3	10,0 x 31,0	14,0 x 21,0	24,3 x 30,3
7,5 x 14,0	10,5 x 14,0	14,0 x 26,0	25,0 x 31,0
7,5 x 16,0	10,5 x 16,0	14,0 x 31,0	25,8 x 30,3
7,5 x 21,0	10,5 x 21,0	14,3 x 20,3	26,5 x 31,0
7,5 x 26,0	10,5 x 26,0	14,3 x 25,3	
7,5 x 31,0	10,5 x 31,0	14,3 x 30,3	

Zum Stanzen von L-Profilen nach DIN 1028 und DIN 1029, Z-Profilen DIN 1027, T-Profilen DIN 1024, IPE-Profilen DIN 1025 Bl., 5
Bei einigen Modellen nur einsetzbar mit Matrizenhalter 50654

Exzenter-Matrize Nr. 60E-3 quer Code 50679 2 3

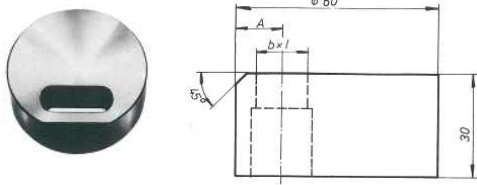

Abmessungen	A	Abmessungen	A
11,3 x 35,3	20,0	19,3 x 40,3	25,0
11,3 x 40,3	24,0	20,0 x 36,0	22,0
12,0 x 36,0	20,5	20,0 x 41,0	25,5
12,0 x 41,0	25,0	20,8 x 35,3	22,0
13,8 x 35,3	20,5	20,8 x 40,3	25,0
13,8 x 40,3	24,0	21,5 x 36,0	22,0
14,5 x 36,0	21,0	21,5 x 41,0	26,0
14,5 x 41,0	25,0	22,8 x 35,3	22,5
14,3 x 35,3	20,5	22,8 x 40,3	25,5
14,3 x 40,3	24,0	23,5 x 36,0	28,0
15,0 x 36,0	21,0	23,5 x 41,0	26,0
15,0 x 41,0	21,0	24,3 x 40,3	26,0
16,3 x 35,3	21,0	25,0 x 41,0	26,0
16,3 x 40,3	24,5	25,8 x 40,3	26,0
17,0 x 36,0	21,5	26,3 x 40,3	26,5
17,0 x 41,0	25,5	26,5 x 41,0	26,5
17,8 x 35,3	21,5	27,0 x 41,0	27,0
17,8 x 40,3	25,0	27,3 x 40,3	27,0
18,5 x 36,0	21,5	28,0 x 41,0	27,5
18,5 x 41,0	25,5		
19,3 x 35,3	21,5		

Exzenter-Matrize Nr. 60E längs Code 50680 2 3

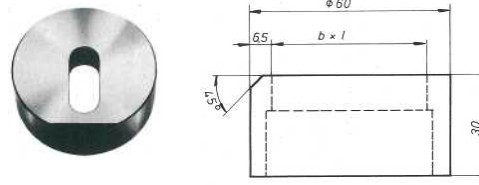

Abmessungen	Abmessungen
11,3 x 35,3	19,3 x 40,3
11,3 x 40,3	20,0 x 36,0
12,0 x 36,0	20,0 x 41,0
12,0 x 41,0	20,8 x 35,3
13,8 x 35,3	20,8 x 40,3
13,8 x 40,3	21,5 x 36,0
14,5 x 36,0	21,5 x 41,0
14,5 x 41,0	22,8 x 35,3
14,3 x 35,3	22,8 x 40,3
14,3 x 40,3	23,5 x 36,0
15,0 x 36,0	23,5 x 41,0
15,0 x 41,0	24,3 x 40,3
16,3 x 35,3	25,0 x 41,0
16,3 x 40,3	25,8 x 40,3
17,0 x 36,0	26,3 x 40,3
17,0 x 41,0	26,5 x 41,0
17,8 x 35,3	27,0 x 41,0
17,8 x 40,3	27,3 x 40,3
18,5 x 36,0	28,0 x 41,0
18,5 x 41,0	
19,3 x 35,3	

Zum Stanzen von L-Profilen nach DIN 1028 und DIN 1029, Z-Profilen
DIN 1027, T-Profilen DIN 1024, IPE-Profilen DIN 1025 Bl., 5

Exzenter-Matrize Nr. 45E quer
Code 50681 1 3

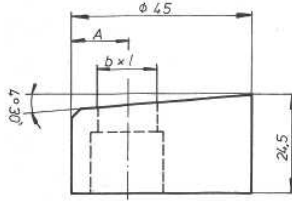

Abmessungen	A	Abmessungen	A
8,0 x 16,0	11,5	13,0 x 21,0	14,0
8,0 x 21,0	12,5	13,0 x 26,0	16,0
8,0 x 26,0	15,0	13,0 x 31,0	19,0
8,0 x 31,0	19,5	14,0 x 21,0	14,5
9,0 x 14,0	11,5	14,0 x 26,0	16,0
9,0 x 17,0	12,0	14,0 x 31,0	20,0
9,0 x 21,0	13,0	14,5 x 21,0	14,5
9,0 x 26,0	15,0	14,5 x 26,0	16,0
9,0 x 31,0	19,5	14,5 x 31,0	20,0
10,0 x 14,0	12,0	15,0 x 21,0	15,0
10,0 x 19,0	12,5	15,0 x 26,0	16,5
10,0 x 21,0	13,0	15,0 x 31,0	20,0
10,0 x 26,0	15,0	17,0 x 26,0	16,5
10,0 x 31,0	19,5	17,0 x 31,0	20,0
10,5 x 14,0	12,0	18,5 x 26,0	17,0
10,5 x 16,0	12,5	18,5 x 31,0	20,0
10,5 x 21,0	13,5	19,0 x 31,0	20,0
10,5 x 26,0	15,5	20,0 x 26,0	17,5
10,5 x 31,0	19,5	20,0 x 31,0	20,5
11,5 x 16,0	12,5	21,5 x 26,0	18,0
11,5 x 22,0	14,0	21,5 x 31,0	20,5
11,5 x 26,0	15,5	23,0 x 31,0	20,5
11,5 x 31,0	19,5	23,5 x 31,0	20,5
12,0 x 16,0	13,0	25,0 x 31,0	21,0
12,0 x 21,0	14,0	26,5 x 31,0	21,0
12,0 x 26,0	15,5		
12,0 x 31,0	19,5		

Zum Stanzen von U-Profilen nach DIN 1026

Exzenter-Matrize Nr. 45E längs
Code 50682 1 3

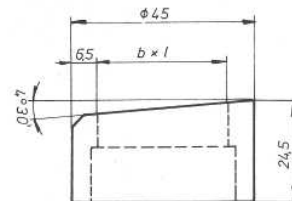

Abmessungen	Abmessungen
8,0 x 16,0	13,0 x 21,0
8,0 x 21,0	13,0 x 26,0
8,0 x 26,0	13,0 x 31,0
8,0 x 31,0	14,0 x 21,0
9,0 x 14,0	14,0 x 26,0
9,0 x 17,0	14,0 x 31,0
9,0 x 21,0	14,5 x 21,0
9,0 x 26,0	14,5 x 26,0
9,0 x 31,0	14,5 x 31,0
10,0 x 14,0	15,0 x 21,0
10,0 x 19,0	15,0 x 26,0
10,0 x 21,0	15,0 x 31,0
10,0 x 26,0	17,0 x 26,0
10,0 x 31,0	17,0 x 31,0
10,5 x 14,0	18,5 x 26,0
10,5 x 16,0	18,5 x 31,0
10,5 x 21,0	19,0 x 31,0
10,5 x 26,0	20,0 x 26,0
10,5 x 31,0	20,0 x 31,0
11,5 x 16,0	21,5 x 26,0
11,5 x 22,0	21,5 x 31,0
11,5 x 26,0	23,0 x 31,0
11,5 x 31,0	23,5 x 31,0
12,0 x 16,0	25,0 x 31,0
12,0 x 21,0	26,5 x 31,0
12,0 x 26,0	
12,0 x 31,0	

Zum Stanzen von U-Profilen nach DIN 1026

Exzenter-Matrize Nr. 60E quer
Code 50681 2 3

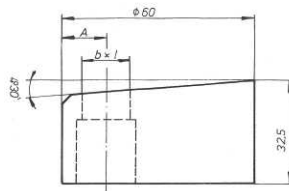

Abmessungen	A
12,0 x 36,0	20,5
12,0 x 41,0	25,0
14,5 x 36,0	21,0
14,5 x 41,0	25,0
15,0 x 36,0	21,0
15,0 x 41,0	25,0
17,0 x 36,0	21,5
17,0 x 41,0	25,5
18,5 x 36,0	21,5
18,5 x 41,0	25,5
20,0 x 36,0	22,0
20,0 x 41,0	25,5
21,5 x 36,0	22,5
21,5 x 41,0	26,0
23,5 x 36,0	23,0
23,5 x 41,0	26,0
25,0 x 41,0	26,0
26,5 x 41,0	26,5
27,0 x 41,0	27,0
28,0 x 41,0	27,5

Zum Stanzen von U-Profilen nach DIN 1026

Exzenter-Matrize Nr. 60E längs
Code 50682 2 3

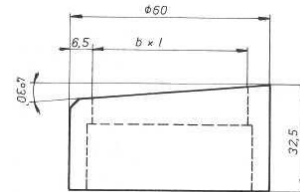

Abmessungen
12,0 x 36,0
12,0 x 41,0
14,5 x 36,0
14,5 x 41,0
15,0 x 36,0
15,0 x 41,0
17,0 x 36,0
17,0 x 41,0
18,5 x 36,0
18,5 x 41,0
20,0 x 36,0
20,0 x 41,0
21,5 x 36,0
21,5 x 41,0
23,5 x 36,0
23,5 x 41,0
25,0 x 41,0
26,5 x 41,0
27,0 x 41,0
28,0 x 41,0

Zum Stanzen von U-Profilen nach DIN 1026

Exzenter-Matrize Nr.45E quer Code 50683 1 3

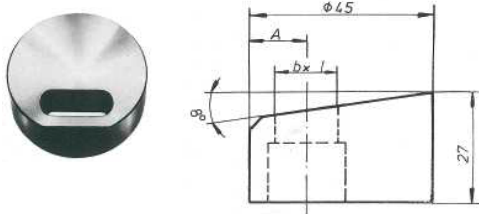

Abmessungen	A	Abmessungen	A
7,5 x 14,0	11,0	12,0 x 21,0	14,0
7,5 x 16,0	11,5	12,0 x 26,0	15,5
7,5 x 21,0	12,5	12,0 x 31,0	19,5
7,5 x 26,0	14,5	13,0 x 21,0	14,0
7,5 x 31,0	19,0	13,0 x 26,0	16,0
8,0 x 21,0	12,5	13,0 x 31,0	19,0
8,0 x 26,0	15,0	14,0 x 21,0	14,5
8,0 x 31,0	19,5	14,0 x 26,0	16,0
8,0 x 16,0	11,5	14,0 x 31,0	20,0
9,0 x 14,0	11,5	14,5 x 21,0	14,5
9,0 x 21,0	13,0	14,5 x 26,0	16,0
9,0 x 26,0	15,0	14,5 x 31,0	20,0
9,0 x 31,0	19,5	15,0 x 21,0	15,0
10,0 x 14,0	12,0	15,0 x 26,0	16,5
10,0 x 19,0	12,5	15,0 x 31,0	20,0
10,0 x 21,0	13,0	17,0 x 26,0	16,5
10,0 x 26,0	15,0	17,0 x 31,0	20,0
10,0 x 31,0	19,5	18,5 x 26,0	17,0
10,5 x 14,0	12,0	18,5 x 31,0	20,0
10,5 x 16,0	12,5	19,0 x 31,0	20,0
10,5 x 26,0	15,5	20,0 x 26,0	17,5
10,5 x 31,0	19,5	20,0 x 31,0	20,5
10,5 x 21,0	13,5	21,5 x 26,0	18,0
11,5 x 16,0	12,5	21,5 x 31,0	20,5
11,5 x 22,0	14,0	23,0 x 31,0	20,5
11,5 x 26,0	15,5	23,5 x 31,0	20,5
11,5 x 31,0	19,5	25,0 x 31,0	21,0
12,0 x 16,0	13,0	26,5 x 31,0	21,0

Zum Stanzen von I-Profilen nach DIN 1026

Exzenter-Matrize Nr. 60E quer Code 50683 2 3

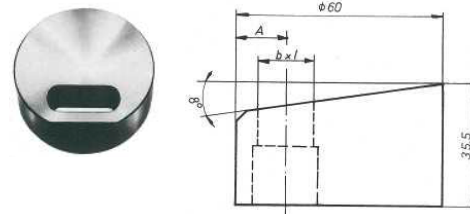

Abmessungen	A
12,0 x 36,0	20,5
12,0 x 41,0	25,0
14,5 x 36,0	21,0
14,5 x 41,0	25,0
15,0 x 36,0	21,0
15,0 x 41,0	25,0
17,0 x 36,0	21,5
17,0 x 41,0	25,5
18,5 x 36,0	21,5
18,5 x 41,0	25,5
20,0 x 36,0	22,0
20,0 x 41,0	25,5
21,5 x 36,0	22,5
21,5 x 41,0	26,0
23,5 x 36,0	23,0
23,5 x 41,0	26,0
25,0 x 41,0	26,0
26,5 x 41,0	26,5
27,0 x 41,0	27,0
28,0 x 41,0	27,5

Zum Stanzen von I -Profilen nach DIN 1026

Überwurfmuttern

Stempelbefestigung mit Mubea-Schnellwechsellspannvorrichtung

Einbaubeispiele für Stempel 50505 1 bis 50505 3 bei Einsatz der Mubea-Schnellwechsellspannvorrichtung mit Reduzierungen.

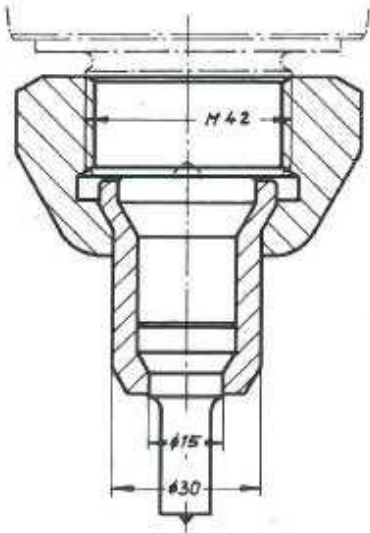

Einbaubeispiel:
Stempelhalter M42 mit
Überwurfmutter 50506 2

Bestimmt zum Einbau von
Stempel 50505 2:
ohne Reduzierung

Stempel 50505 1:
mit Reduzierung 50531 3 und
Stempelbeilage 50529

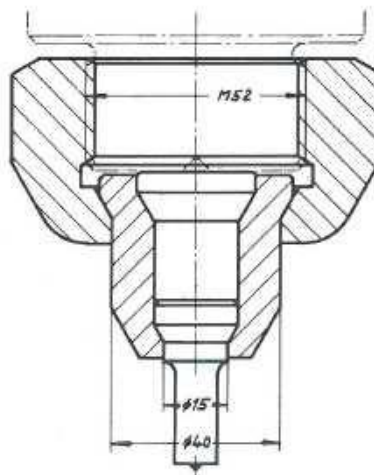

Einbaubeispiel:
Stempelhalter M52 mit
Überwurfmutter 50506 4

Bestimmt zum Einbau von
Stempel 50505 3:
ohne Reduzierung

Stempel 50505 2:
mit Reduzierung 50531 5

Stempel 50505 1:
mit Reduzierung 50531 4 und
Stempelbeilage 50529

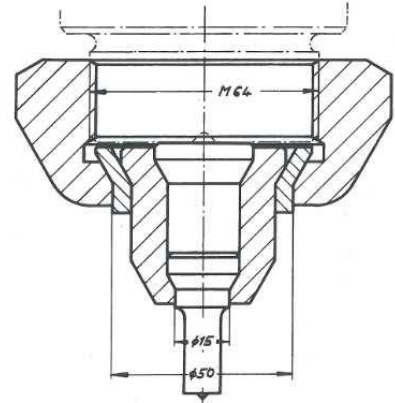

Einbaubeispiel:
Stempelhalter M64 mit
Überwurfmutter 50506 7

Bestimmt zum Einbau von
Stempel 50505 4:
ohne Reduzierung

Stempel 50505 3:
mit Reduzierung 50531 2

Stempel 50505 2:
mit Reduzierung 50531 1

Stempel 50505 1:
mit Reduzierung 50531 2,
Reduzierung 50531 4 und
Stempelbeilage 50529

Überwurfmutter M42
Für Stempel 50505 2 im Lochbereich von
15,5 – 30,0 mm
Code 50506 2

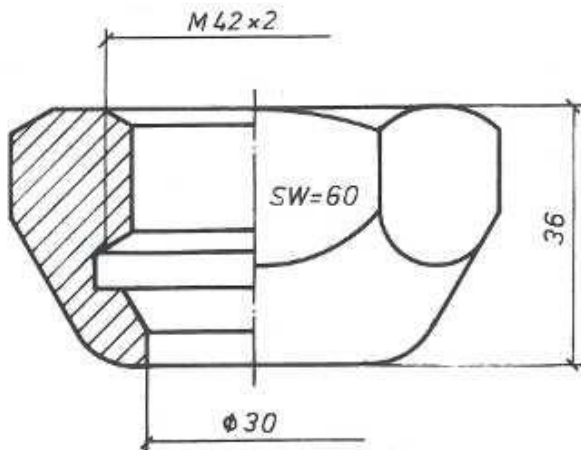

Überwurfmutter M52
Für Stempel 50505 2 im Lochbereich von
15,5 – 30,0 mm
Code 50506 3

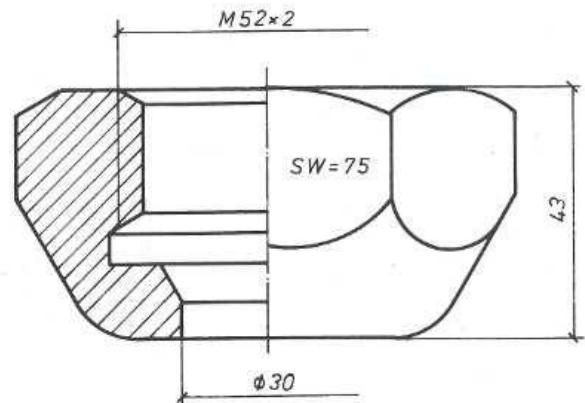

Überwurfmutter M52
Für Stempel 50505 3 im Lochbereich von
30,5 – 40,0 mm
Code 50506 4

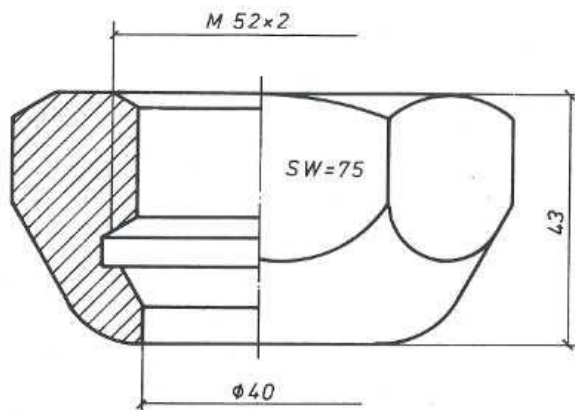

Überwurfmutter M64
Für Stempel 50505 4 im Lochbereich von
40,5 – 50,0 mm
Code 50506 7

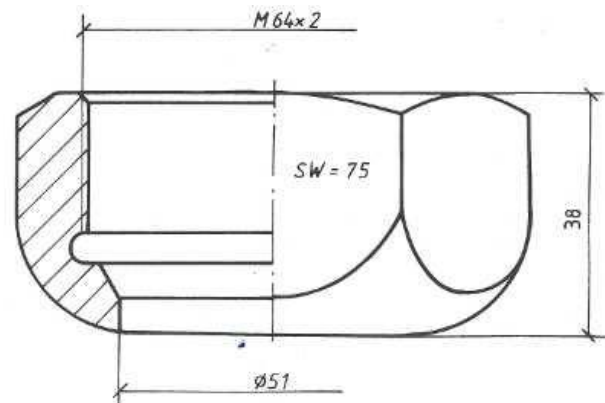

Reduzierungen für Stempel 50505

Stempelbeilage für Stempel 50505 1 im Lochbereich 3 – 15 mm
Einbau mit Reduzierungen 50531
Code 50529

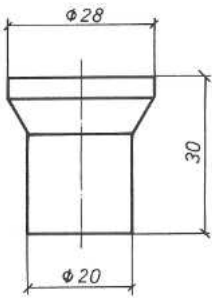

Reduzierung für Mubea-Schnellwechsel-Spannvorrichtung und Überwurfmutter M42, für Stempel 50505 1 im Lochbereich 3 – 15 mm
Code 50531 3

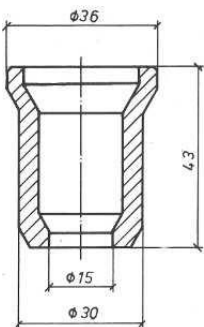

Reduzierung für Mubea-Schnellwechsel-Spannvorrichtung und Überwurfmutter M52, für Stempel 50505 1 im Lochbereich 3 – 15 mm
Code 50531 4

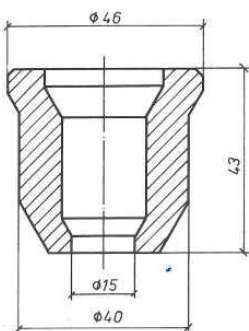

Reduzierung für Mubea-Schnellwechsel-Spannvorrichtung und Überwurfmutter M52, für Stempel 50505 2 im Lochbereich 15,5-30,0 mm
Code 50531 5

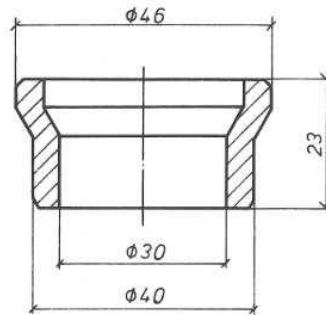

Reduzierung für Überwurfmutter M64, für Stempel 50505 2 im Lochbereich 15,5-30,0 mm
Code 50531 1

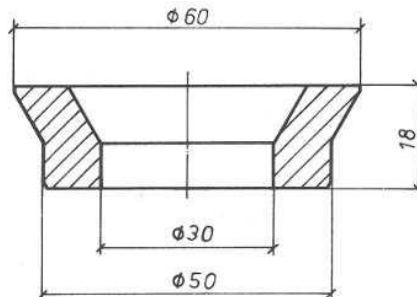

Reduzierung für Überwurfmutter M64, für Stempel 50505 3 im Lochbereich 30,5-40,0 mm
Code 50531 2

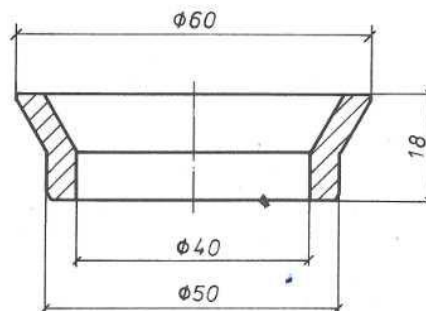

Matrizenhalter

Code 50606 1

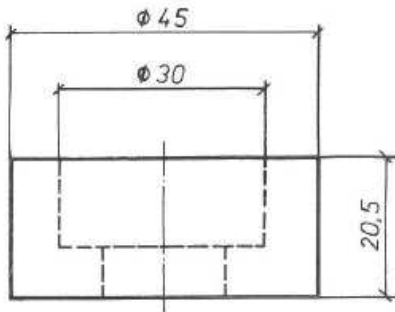

Code 50606 2

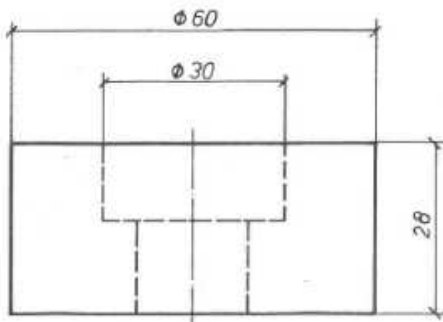

Code 50606 3

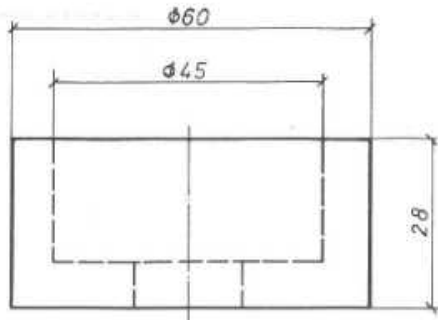

Code 50654

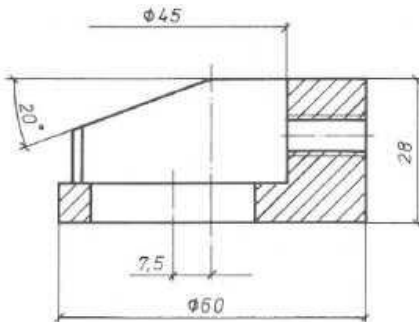

Code 50606 4

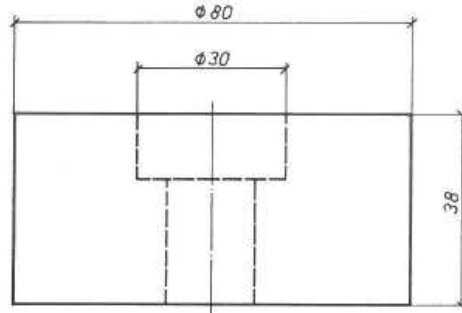

Code 50606 5

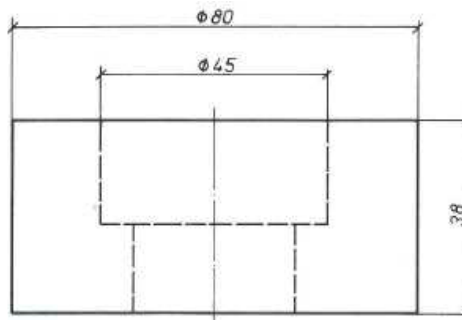

Code 50606 6

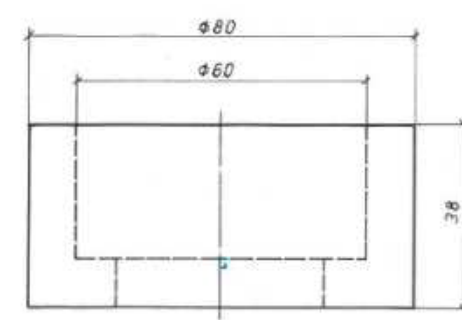

Code 50607

